

OPAL-RT TECHNOLOGIES

HIL real-time simulation for Power Systems & Power Electronics



OPAL-RT
TECHNOLOGIES

NICE TO MEET YOU!



Paulina Uryasz

Business Development Manager
OPAL-RT Poland

paulina.uryasz@opal-rt.com



Aleksandra Lis

F&E Engineer
OPAL-RT Poland

Aleksandra.Lis@opal-rt.com



Pierre-Yves Robert

Strategic Technical Manager and
Software Architect Engineer
OPAL-RT Germany

pierre-yves.robert@opal-rt.com



Real-Time Digital
Simulators



Design, validation &
optimization of complex
control systems



World leader in the development of **real-time digital simulators** based on **PC** and **FPGA** technologies



OBJECTIVE

DESIGN, TEST & VALIDATE COMPLEX CONTROL SYSTEMS BEFORE PHYSICAL TESTING

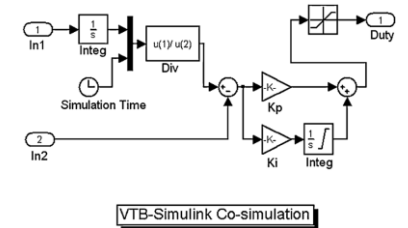

CONTROL
ALGORITHMS

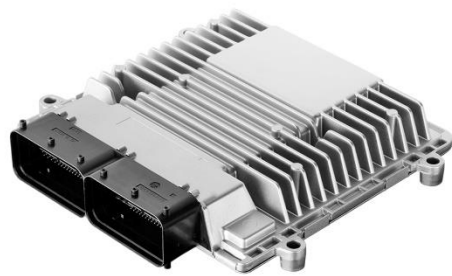

ECU



PROTECTION RELAYS



BMS



MICROGRID
CONTROL

OUR OFFICES

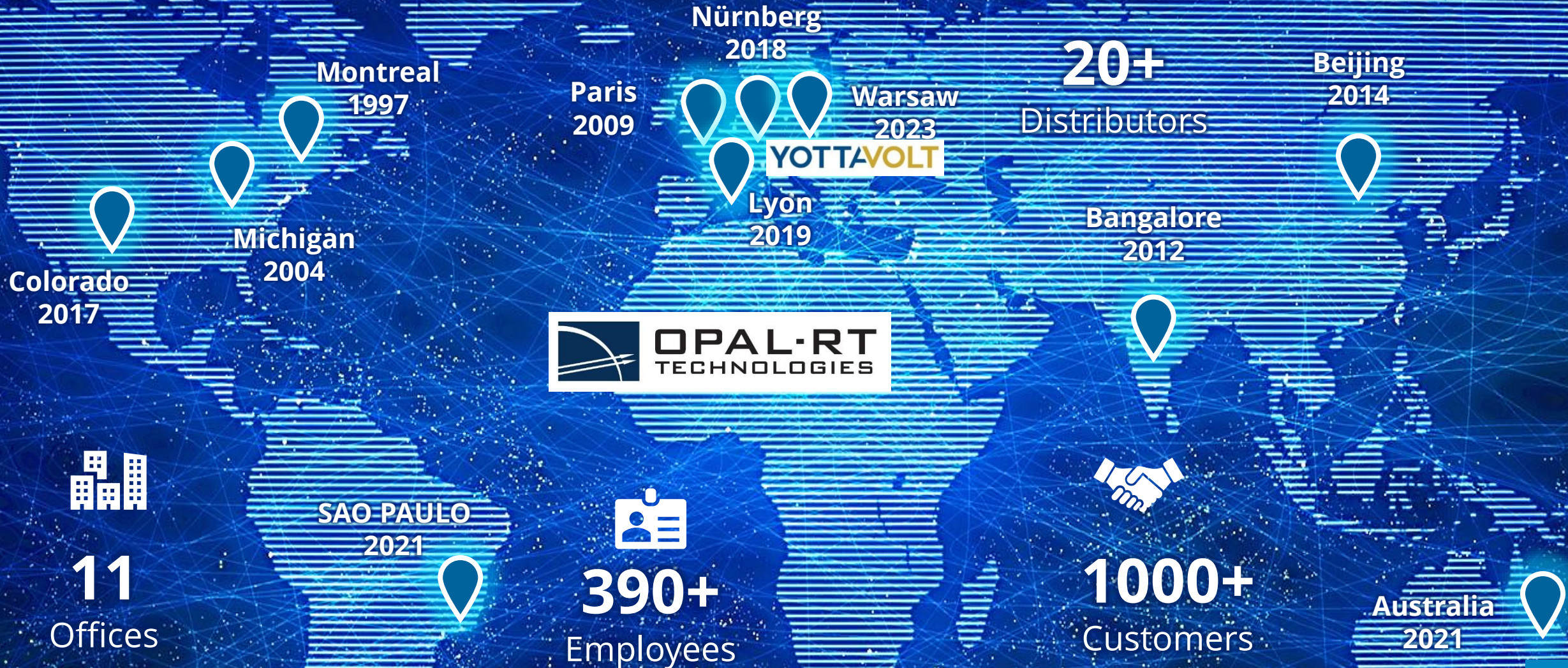

FROM COMPACT SIMULATORS

TO LARGE INTEGRATED
TEST BENCHES



OUR BUSINESS

Trainings

Trainings which allow our customer to use real-time simulators autonomously

On-site trainings / e-learning platform



Technical support

Local field application engineers teams

Bring support to our customers



Real-time simulation expertise

Models development

Consulting

Specific trainings



OUR CUSTOMERS



ENERGY



TRANSPORT

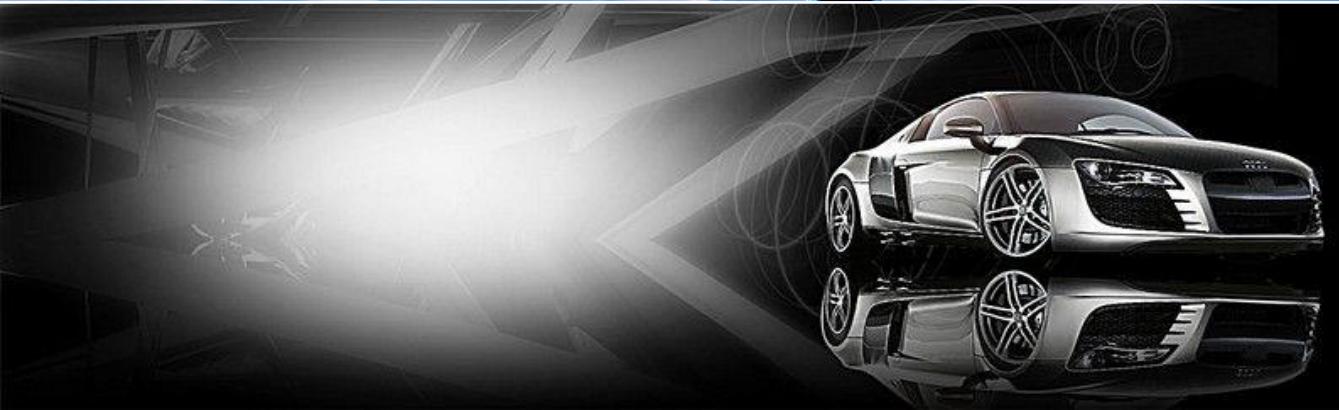

AUTOMOTIVE

INDUSTRIAL



R&D
CENTRES



ACADEMIC

MAIN APPLICATIONS



OUR CUSTOMERS (SAMPLE)





Complex industrial electrical and electromechanical systems
Complex systems studied through virtual models



Fast evolution of technologies
Flexibility of models which can be upgraded

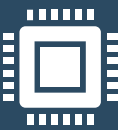

More complex and sophisticated control strategies
Control can also be simulated, as well as its interactions with the plant system



Huge validation effort required
Validation can be progressive, from design phase and highly automated



On-field tests hard to conduct
Many tests can be carried out in the lab with a virtual environment



Uniqueness of some projects
Models can be adapted to any unique project



Related validations can compromise the project
Validation can be progressive, from design phase



Shorter development time
More lab tests starting early reduce need for rework or waiting for parts



Dangerous test cases
Dangerous scenarios are simulated and studied thoroughly



Cost optimisation
Less prototypes, less destructive tests, more virtual configurations, less risk

SOLUTION: REAL-TIME SIMULATION – OVERVIEW

- 1. Design of the model
- 4. Simulation Management

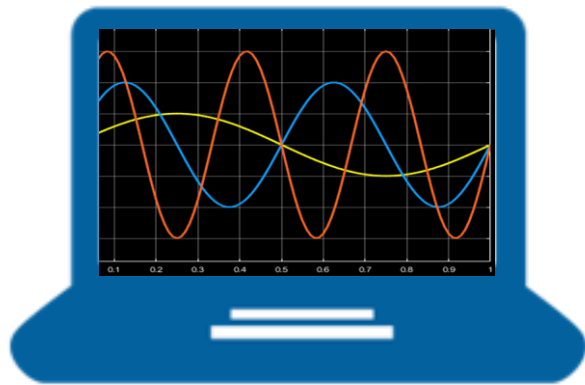

Windows host PC

- 2. Model execution on Real-time simulator

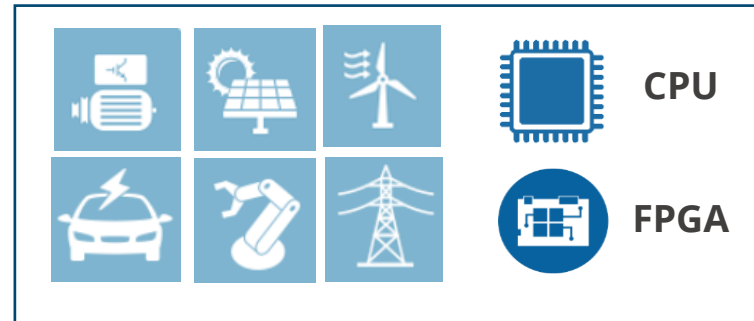

Real-time simulator
Simulation on
multicore processor & FPGA
Inputs/Outputs/ Com. protocols

- 3. Devices under test

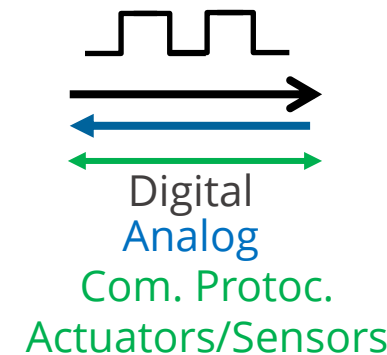

Controller, protection,
machines

MULTI-APPLICATIONS PLATFORM

MODEL/SOFTWARE-IN-THE-LOOP

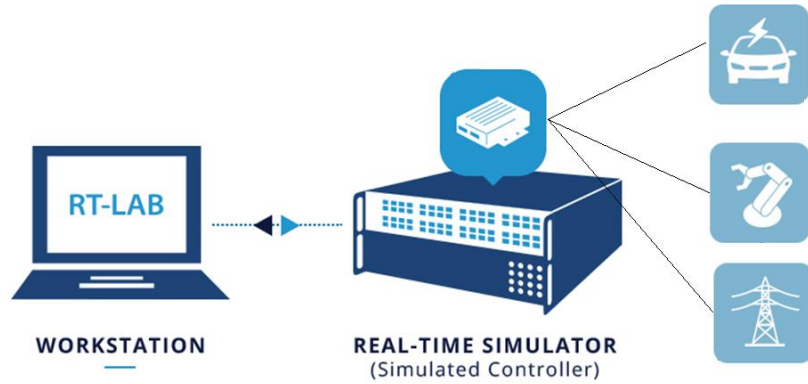

RAPID CONTROL PROTOTYPING

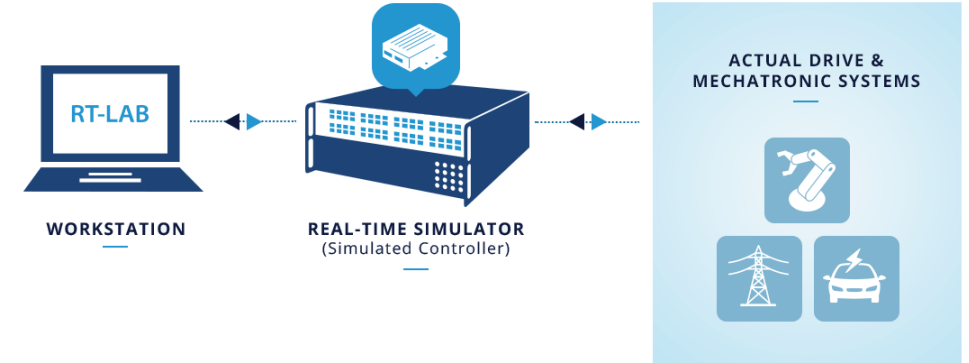

HARDWARE-IN-THE-LOOP

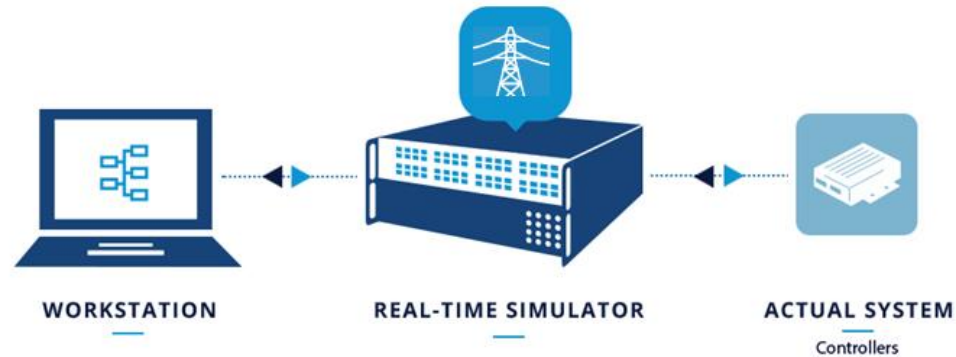

POWER HIL

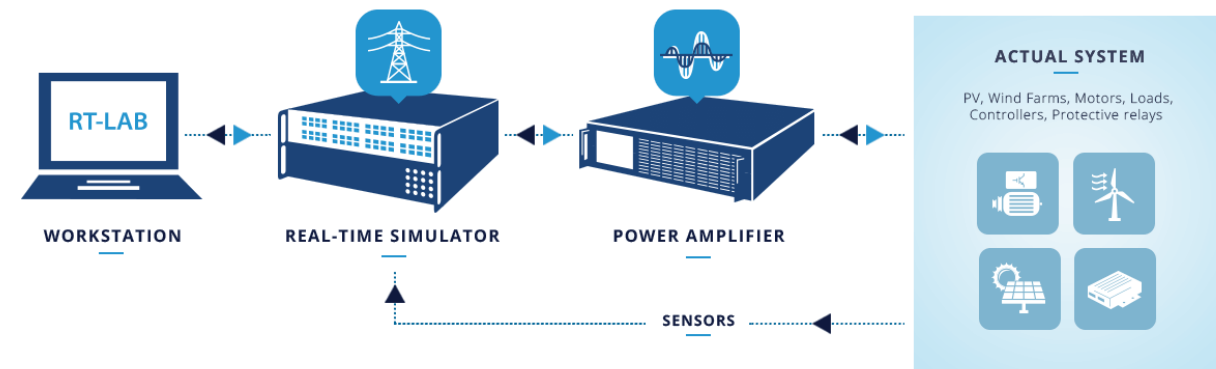

ELECTRICAL VEHICLE



Customer - Valeo (France)

Project - Electrical Drive within vehicle

Objectives - **Control algorithms testing**

Solution - OPAL-RT **Rapid-Control-Prototyping** (RCP real-time simulator)

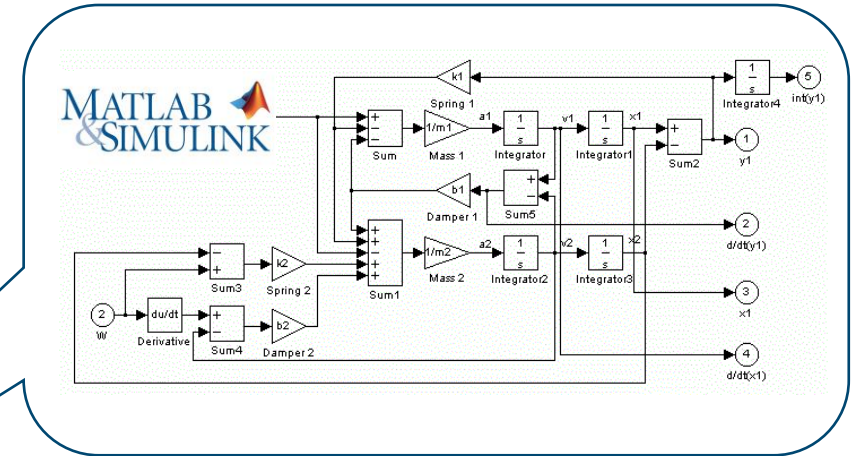

WORKSTATION
Simulation management
Time step 50us



SIMULATED CONTROLLER
Rapid Control-Prototyping (FPGA)
Algorithms, logic

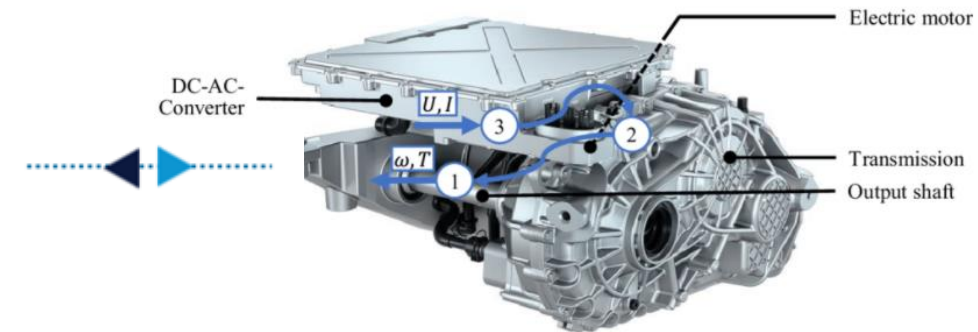

REAL ELECTRICAL DRIVE
Valeo device to be controlled

POWER SYSTEMS



Customer – R&D Nester REN (Portugal)

Project - Validation of protection relays for distribution grids

Objectives - **Protection relay testing**

Solution - OPAL-RT **Hardware-In-The-Loop** (HIL real-time simulator)



WORKSTATION
Simulation management
Time step 50us



SIMULATED PLANT
Hardware-In-The-Loop (CPU)
Electrical grid



REAL PROTECTION UNDER TEST
Protection

EMBEDDED POWER ELECTRONICS



Customer - SNCF (France)

Project - TGV new commercial speed 350 Km/h

Objectives - Train traction system **controllers testing**

Solution - OPAL-RT **Hardware-In-The-Loop** (HIL real-time simulator)

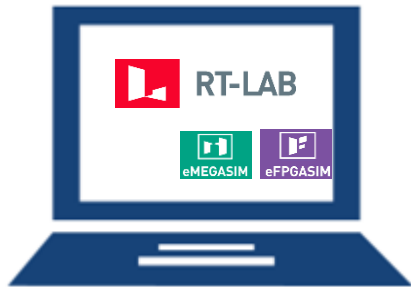

WORKSTATION

Simulation management

Time step grid 50us

Time step converter below 1us



SIMULATED PLANT

*Hardware-In-The-Loop (FPGA)
Train traction system (HT & BT)*



REAL CONTROLLERS UNDER TEST

SNCF controllers

POWER SYSTEMS



Customer - EDF (France)

Project - Plateforme énergies réparties

Objectives - **Microgrid impact on distribution grid**

Solution - OPAL-RT **Power Hardware-In-The-Loop** real-time simulator

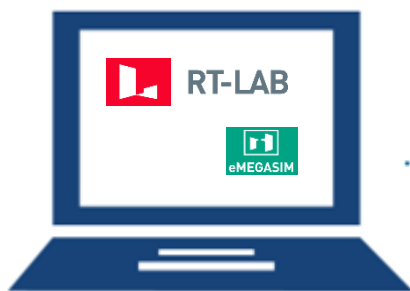

WORKSTATION

*Simulation management
Time step 50us*



SIMULATED GRID & CONTROL

*Hardware-In-The-Loop & Rapid-Control-Prototyping (CPU)
Control algorithms & Electrical grids*

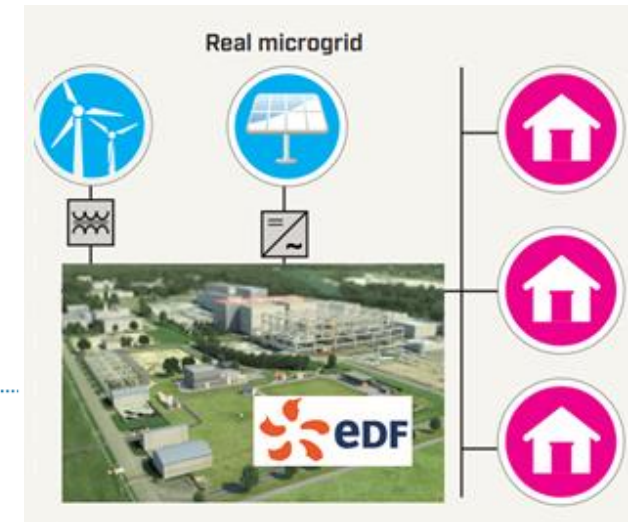

REAL MICROGRID

EDF microgrid

THE PRODUCTS

OUR HARDWARE... IN A NUTSHELL

SIMULATION PLATFORMS & IO

Powerful, flexible, scalable, upgradable computation systems with hardware I/O capabilities

Modular

Powerful

CPU
FPGA

I/Os

Scalable

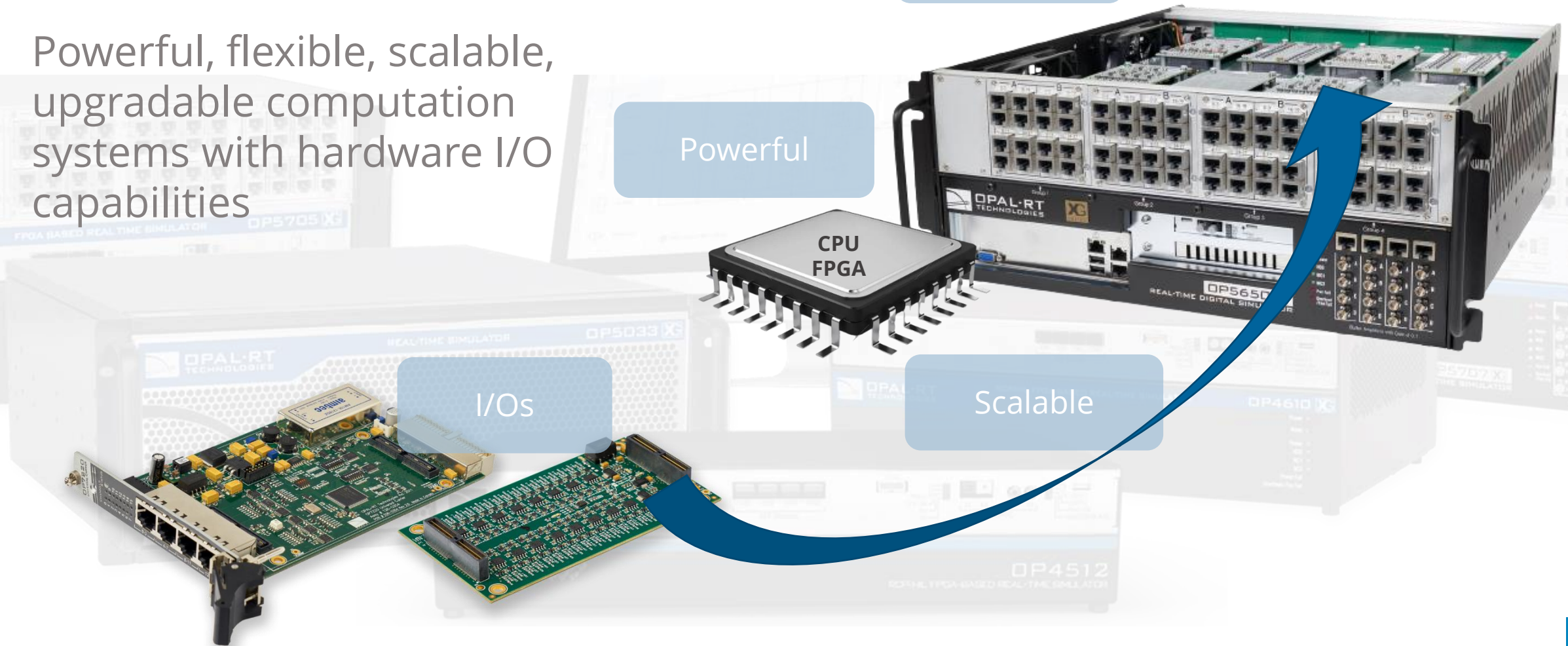

HIL TO GO (H2G)



Entry-level

H2G-100



Compact mid-range

H2G-200



Modular & expandable

H2G-310



Large-scale HIL

H2G-410

General

Hardware platform	OP4512	OP4610XG	OP5020XG + OP4810-IO	OP5025XG + OP4810-IO
Software platform	RT-LAB	RT-LAB	RT-LAB	HYPERSIM
CPU cores	Intel 4 cores – 3.7 GHz	AMD 6 cores – 3.8 GHz	Intel 4 cores – 3.7 GHz	AMD 6 cores – 3.8 GHz
FPGA	Kintex7® - 410T	Kintex7® - 410T	VERSAL® VM1302 – 703K	VERSAL® VM1302 – 703K
HOST license	✓	✓	✓	✓
Real-time core activated	3 cores	3 cores	3 cores	Hypersim Core Basic 60 single-phase nodes (expandable to 240 single-phase nodes)
Software toolbox	eHSx16 Standard	eHSx16 Standard	eHSx16 Standard	eHSx16 Standard

I/O

Digital	32 DIO	64 DIO	64 DIO TTL	32DI 30V/32DO 30V
Analog	16 AIN – 2 MSPS 16 AOUT – 1 MSPS	16 AIN – 2 MSPS 16 AOUT – 1 MSPS	32 AIN – 5 MSPS 32 AOUT – 10 MSPS	16 AIN – 2 MSPS 48 AOUT – 1 MSPS
Total I/O counts	64	96	128	128



RT-LAB

**MULTI-DOMAIN, FLEXIBLE, SCALABLE
SIMULATION PLATFORM**

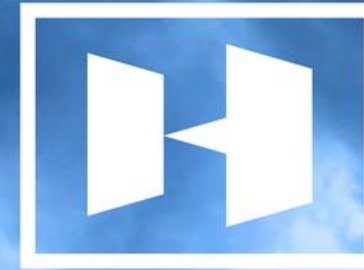

HYPERSIM

**POWERFUL POWER SYSTEMS SIMULATION
PLATFORM**

eHS (electric Hardware Solver)



eFPGASIM

Facilitates the process from circuit model to high fidelity FPGA simulation ($T_s < 1\mu s$)

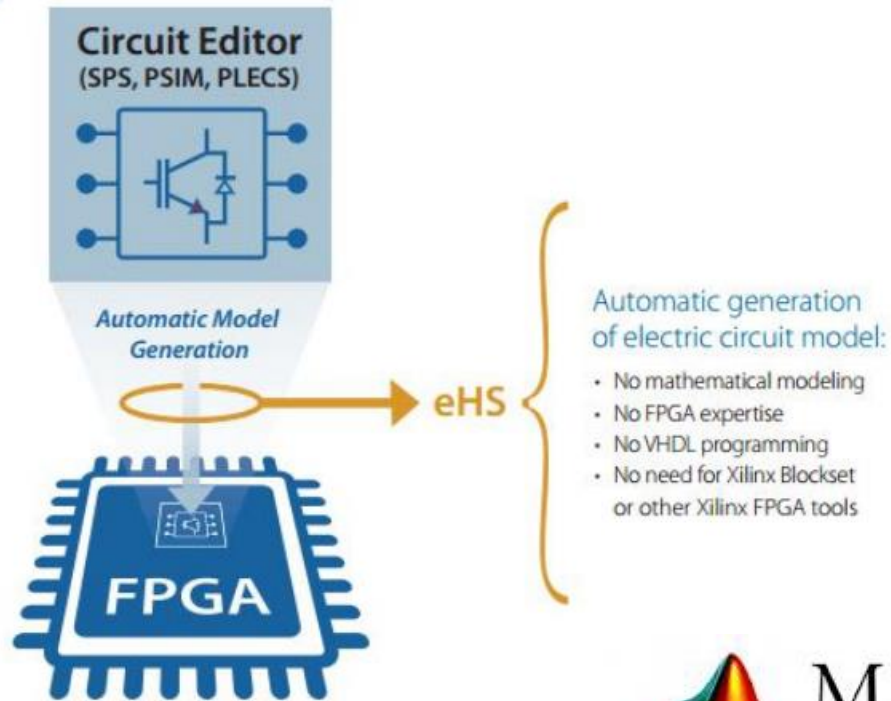

- Design your circuit using your favorite editor (SimScape SimPowerSystems , PLECS, PSIM, MultiSim)
- Scenarios feature allows you to change circuit parameters (L,C,R values) during real-time simulation. Allowing you to test all sorts of scenarios



[MORE INFORMATION](#)

REACH UNRIVALED PERFORMANCE ON FPGA

**POWER
ELECTRONICS
MODELS**
UP TO 144
SWITCHES

**MIN. RT SIMU
TIME STEP**
90ns

**MAX.
SWITCHING
FRQUENCY**
1 MHz

**ELECTRICAL
MACHINES
LIBRARY**
UP TO 8
MACHINES IN //

**DETAILED
CONVERTERS
(1PH/3PH)**
24/8



& eHS DEMO

THANK YOU!

MORE INFORMATION

Contact: paulina.uryasz@opal-rt.com

Tel. +48 663 409 080



OPAL-RT
TECHNOLOGIES